

PKR-RP Residue Pump

EQUIPMENT HIGHLIGHTS

- 1,000-7,500 kg/hr (2,200-16,500 lbs/hr) capacity.
- 6" Solid machined feed screw.
- 3" Triclamp connection.
- Right, left, or up outlet discharge position.
- Single vane with 3" solid machined rotor.
- Rolling or stationary base available.

**“POSS Pumps
Maintain Low Cost of
Ownership, Easy
Setup, and Compact
Footprints”**

POSS Design Limited
“World Leader in Quality Separation Solutions since 1978”

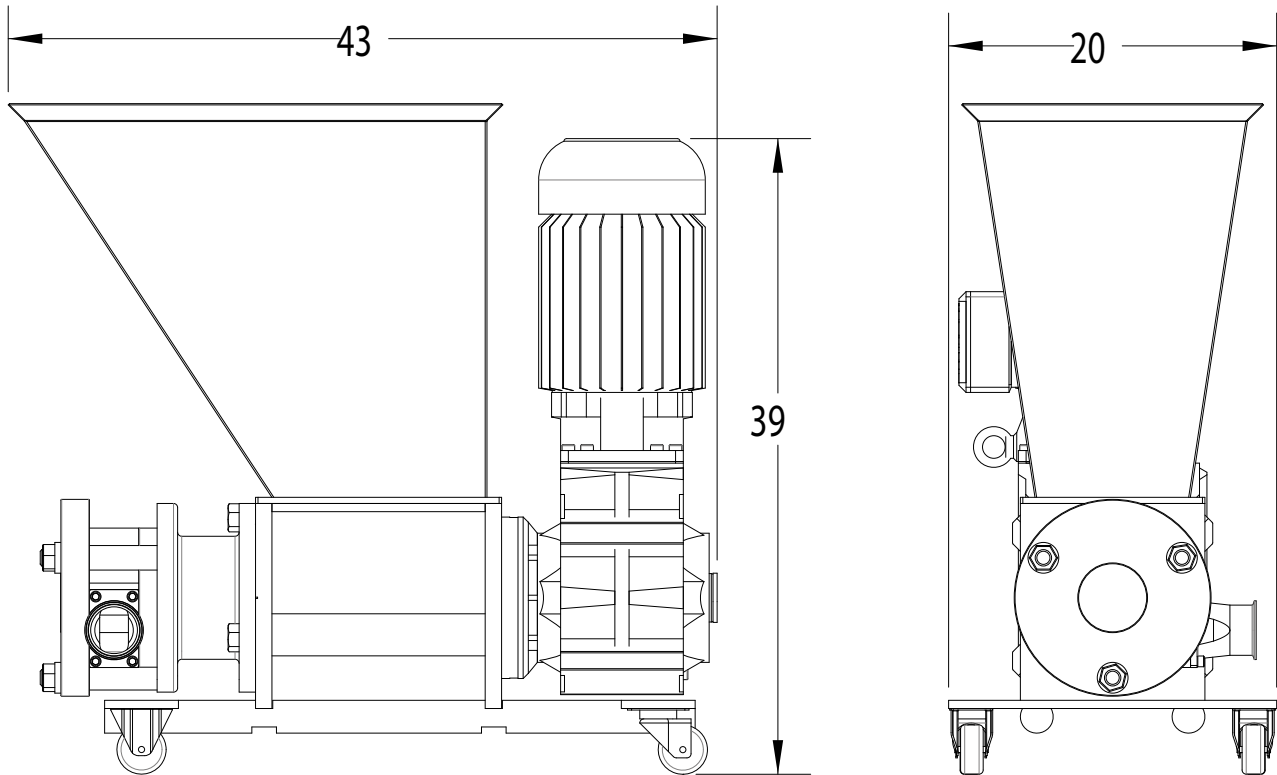

PKR-RP Residue Pump

TECH SPECS

INPUT CAPACITY Up to 7,500 kg/hr (16,500 lbs/hr)

*IDEAL FOR PUMPING RESIDUE OR WHOLE MUSCLE

MACHINE POWER 15-20 hp (11-15 kW)

TRANSMISSION Direct Drive

HOPPER AGITATOR Optional

HOPPER EXTENSION Fully Customizable

DRIVE OPTIONS Full Stainless or Painted Available

CONTROLS Washdown VFD or Simple Start/Stop

NOTES:

POSS Design Limited
"World Leader in Quality Separation Solutions since 1978"