

ProMax 1200C

EQUIPMENT HIGHLIGHTS

- 1,200 kg/hr (2,600 lbs/hr) input capacity.
- 6" Separation screw (single or dual screws).
- 10" Head length (screen plates or perforated).
- 10-20 hp (7.5-15 kW) Motor.
- POSS Manual Restrictor.
- Integrated head cover & residue chute.

“POSS Maintains the Highest Yields and Lowest Temperature Rise in the Industry”

POSS Design Limited
 “World Leader in Quality Separation Solutions since 1978”

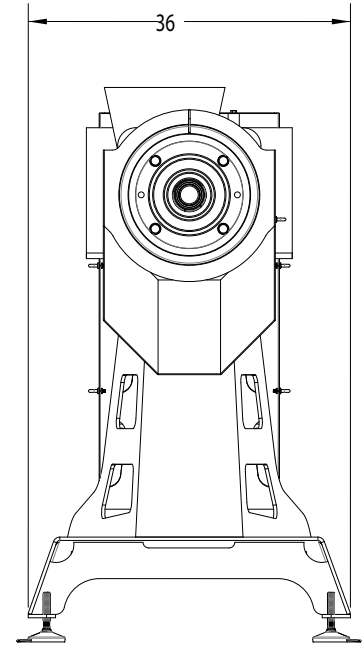
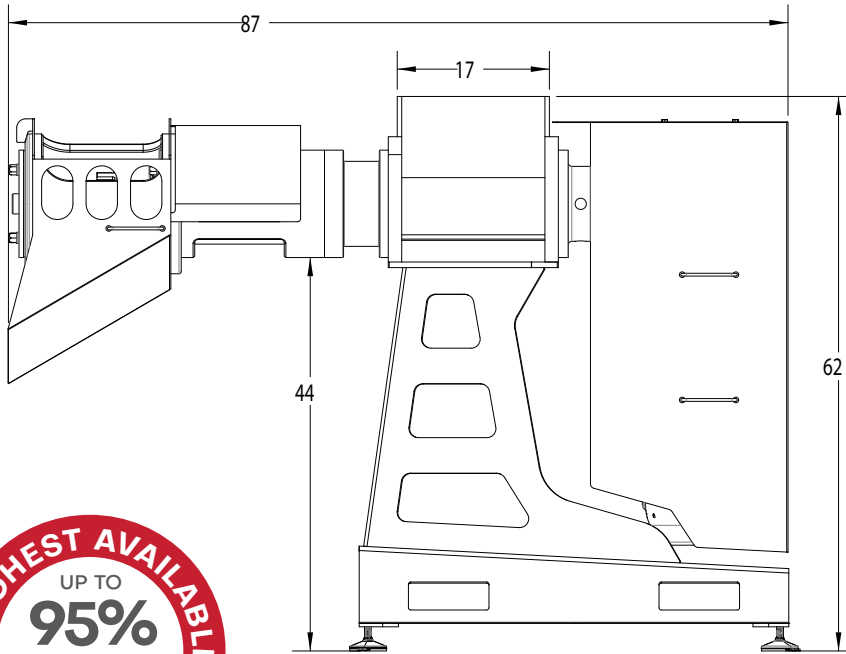

ProMax 1200C

TECH SPECS

INPUT CAPACITY	Up to 1,200 kg/hr (2,600 lbs/hr)
STANDARD CONFIGURATION	6" Single or Dual Screws
MACHINE POWER	10-20 hp (7.5-15 kW)
TRANSMISSION	Direct Extruder Drive
HOPPER GEOMETRY	17" x 13"
HOPPER EXTENSION	Customizable
HEAD GEOMETRY	6" x 10"
CONTROLS	HMI Control Panel with Line Integration or Simple Start/Stop

NOTES:

POSS Design Limited
 "World Leader in Quality Separation Solutions since 1978"