

# ProMax 1500

## EQUIPMENT HIGHLIGHTS

- 1,500 kg/hr (3,300 lbs/hr) input capacity.
- 5" Separation screw (single or dual screws).
- 8" Head length (screen plates or perforated).
- 20-30 hp (15-22 kW) Motor.
- POSS Manual Restrictor.
- Integrated head cover & residue chute.

**“POSS Maintains the Highest Yields and Lowest Temperature Rise in the Industry”**

POSS Design Limited  
 “World Leader in Quality Separation Solutions since 1978”

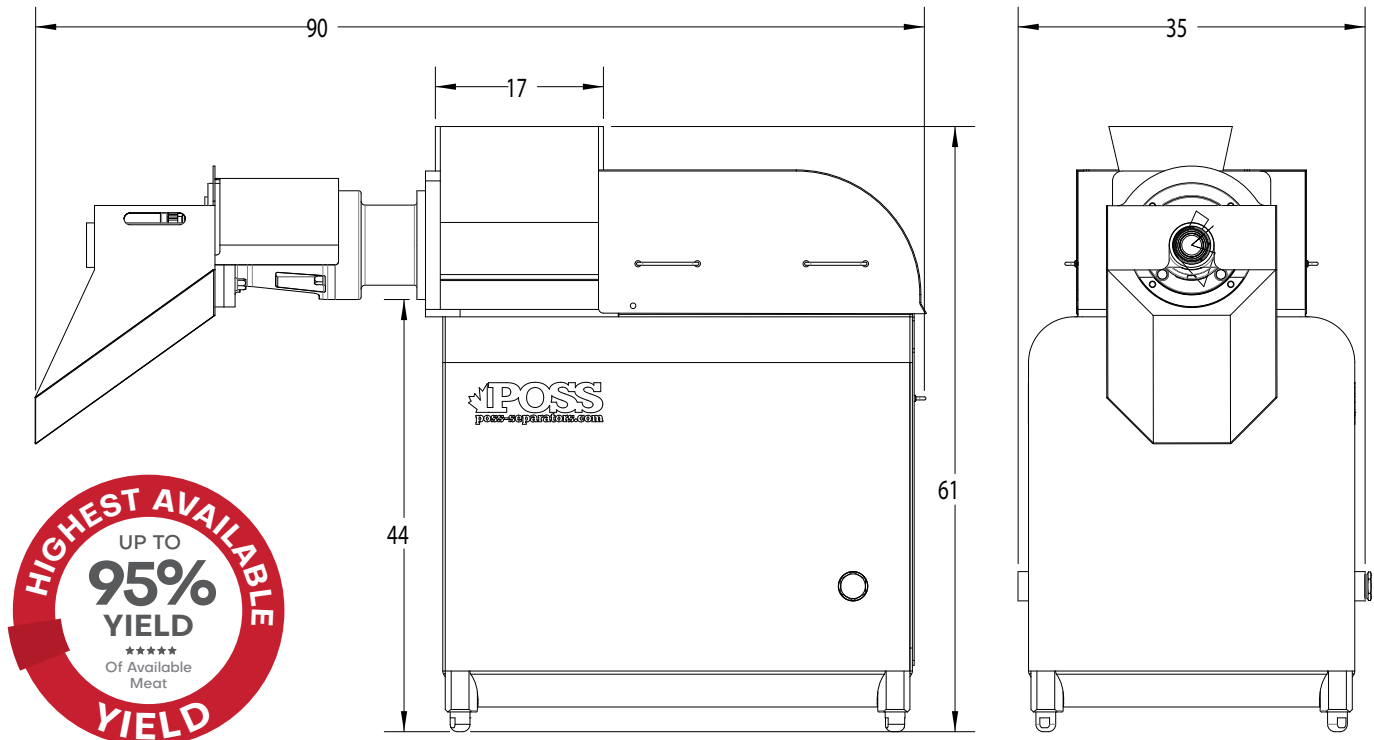

# ProMax 1500

## TECH SPECS

INPUT CAPACITY	Up to 1,500 kg/hr (3,300 lbs/hr)
STANDARD CONFIGURATION	5" Single or Dual Screws
MACHINE POWER	20-30 hp (15-22 kW)
TRANSMISSION	Extruder Belt Drive
HOPPER GEOMETRY	17" x 12"
HOPPER EXTENSION	Customizable
HEAD GEOMETRY	5" x 8"
CONTROLS	HMI Control Panel with Line Integration or Simple Start/Stop

## NOTES:

---

---

---

---

---

---

---

---

POSS Design Limited  
 "World Leader in Quality Separation Solutions since 1978"