



ProMax 9000

EQUIPMENT HIGHLIGHTS

- 17,000 kg/hr (37,400 lbs/hr) input capacity.
- 9" Separation screw.
- 14" Head length (screen plates or perforated).
- 150-200 hp (110-150 kW) Motor.
- POSS Auto Restrictor option available.
- Integrated assembly crane.

“POSS Maintains the Highest Yields and Lowest Temperature Rise in the Industry”

POSS Design Limited
 “World Leader in Quality Separation Solutions since 1978”

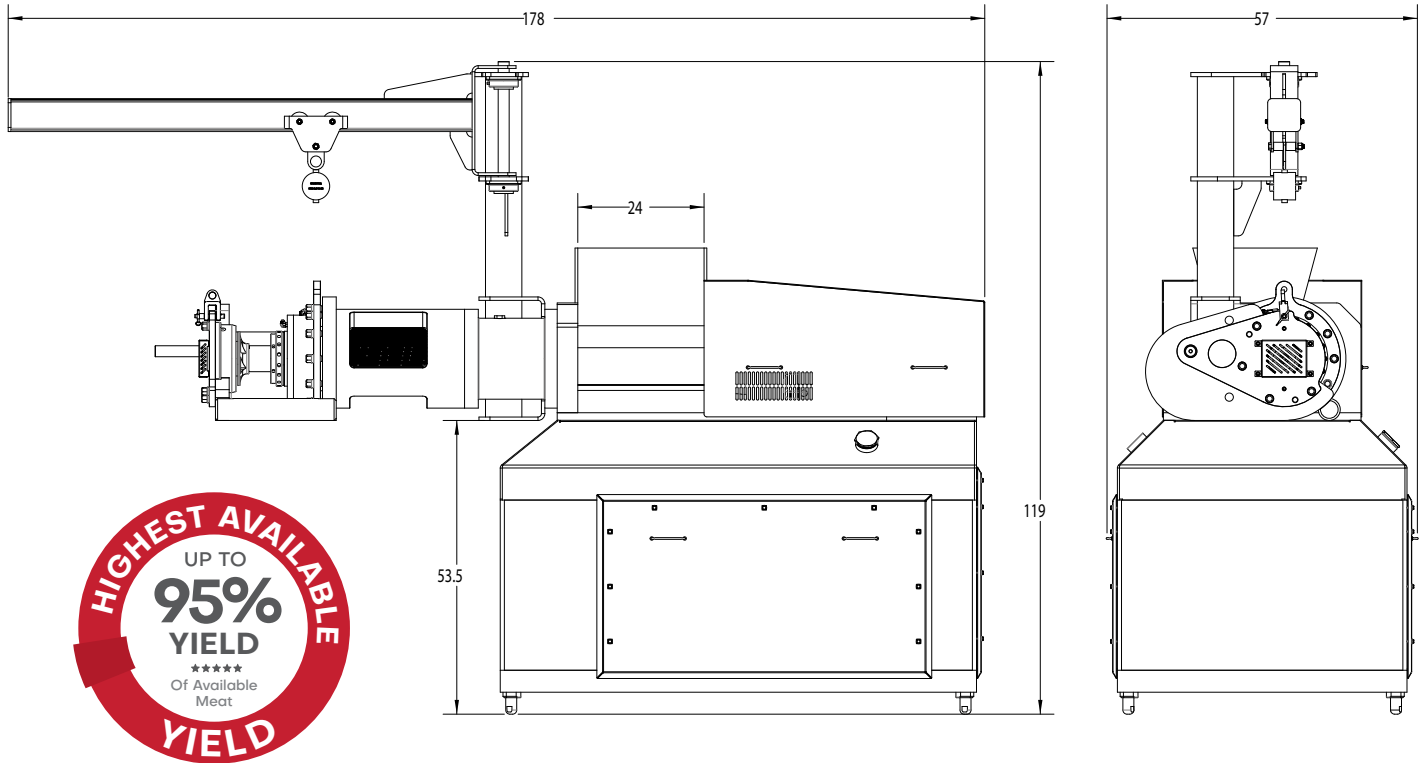

ProMax 9000

TECH SPECS

INPUT CAPACITY	Up to 17,000kg/hr (37,400lbs/hr)
STANDARD CONFIGURATION	9" Dual Screw Setup
MACHINE POWER	150-200hp (110-150kW)
TRANSMISSION	Extruder Belt Drive
HOPPER GEOMETRY	24" x 22"
HOPPER EXTENSION	Customizable
HEAD GEOMETRY	9" x 14"
CONTROLS	HMI Control Panel with line integration

NOTES:

POSS Design Limited
 "World Leader in Quality Separation Solutions since 1978"