

# Blender

## EQUIPMENT HIGHLIGHTS

- 1,000-2,000 kg (2,200-4,400 lbs) capacity.
- 68" Discharge height.
- Electronic or hydraulic load cells available.
- Ribbon or paddle construction available.
- Heavy duty SS, open channel design.
- CO2 & vacuum options available.

**“POSS Blenders  
Implement Sanitary  
Design and Require  
Low Maintenance”**

“World Leader in Quality Separation Solutions since 1978”



A DURAVANT COMPANY

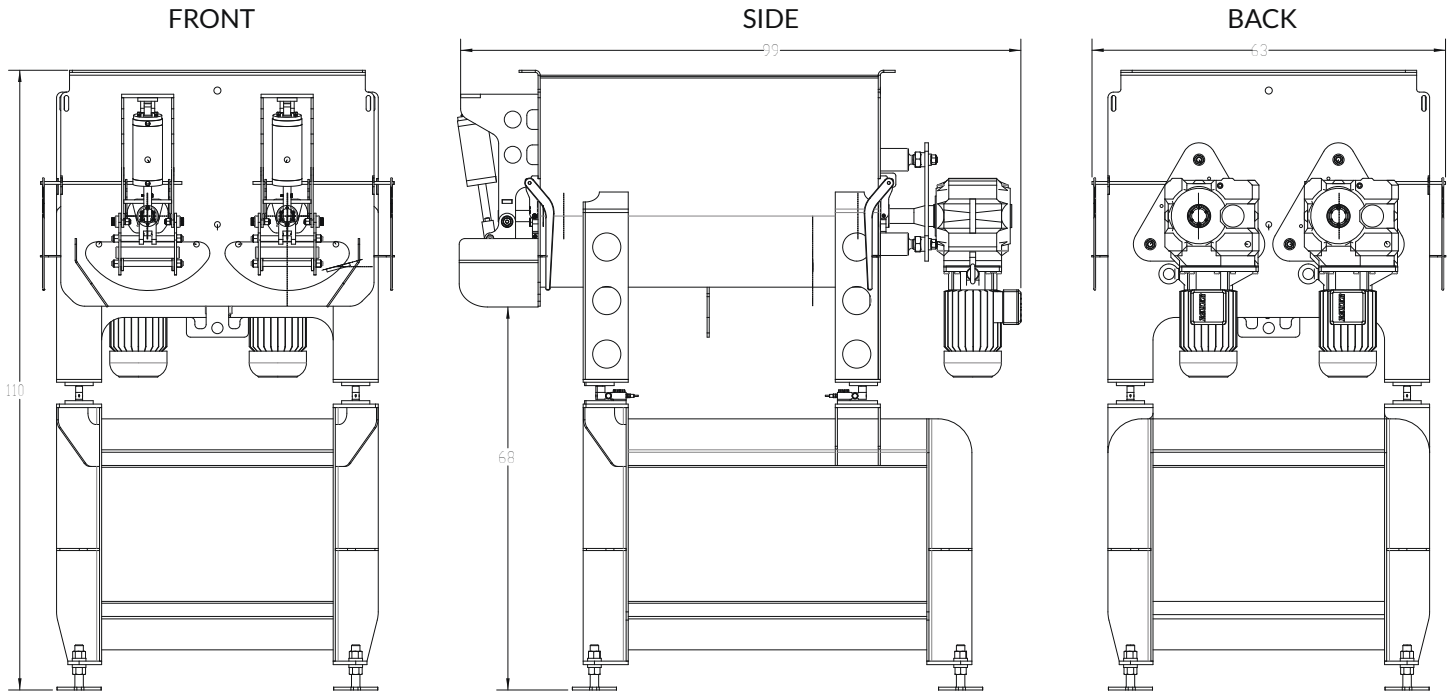

# Blender

## TECH SPECS

CAPACITY Up to 2,000 kg (4,400 lbs)

FOOTPRINT Variable

DRIVES Direct Coupled Drive

POWER REQUIREMENT 2 x 10 hp (7.5 kW)

DOOR MECHANISM 2 x 5" SS Pneumatic Cylinders

SAFETY Integrated Safety Grate

SANITATION Quick-Release Shaft Seals

CONTROLS Stand Alone or Integrated Controls

## NOTES:

---

---

---

---

---

---

---

---

"World Leader in Quality Separation Solutions since 1978"