

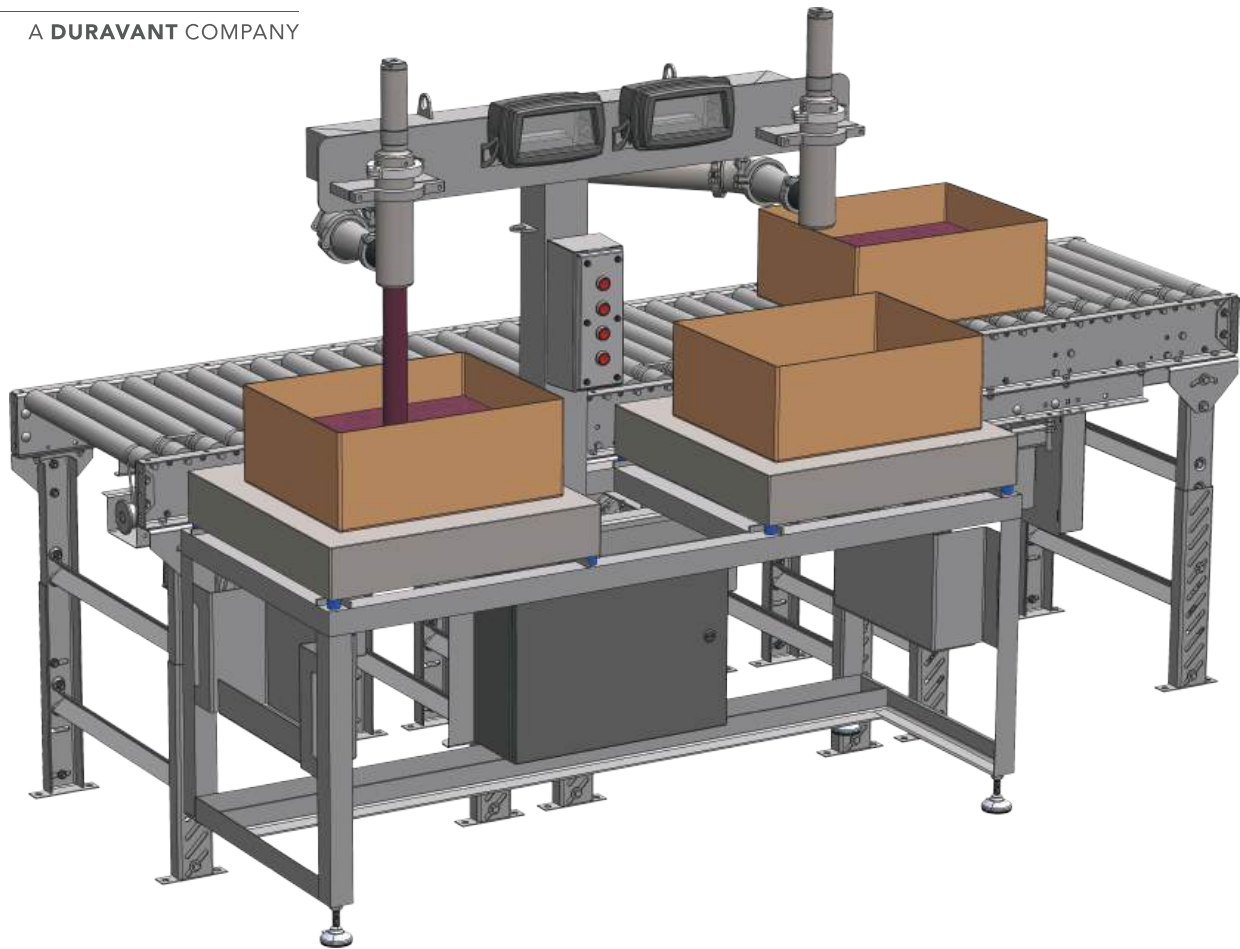

A DURAVANT COMPANY



Box Filling Station

EQUIPMENT HIGHLIGHTS

- 1,000 -10,000 kg/hr (2,200-22,000 lbs/hr) capacity.
- Full Sanitary Design.
- 3" Triclamp connection.
- Auto-alternating product filling (plunger cutoff).
- Single or dual box filling stations available.
- +/- 2% Fill accuracy.

“POSS Box Filling Stations Maintain Low Cost of Ownership, Easy Setup, and Compact Footprints”

“World Leader in Quality Separation Solutions since 1978”



A DURAVANT COMPANY

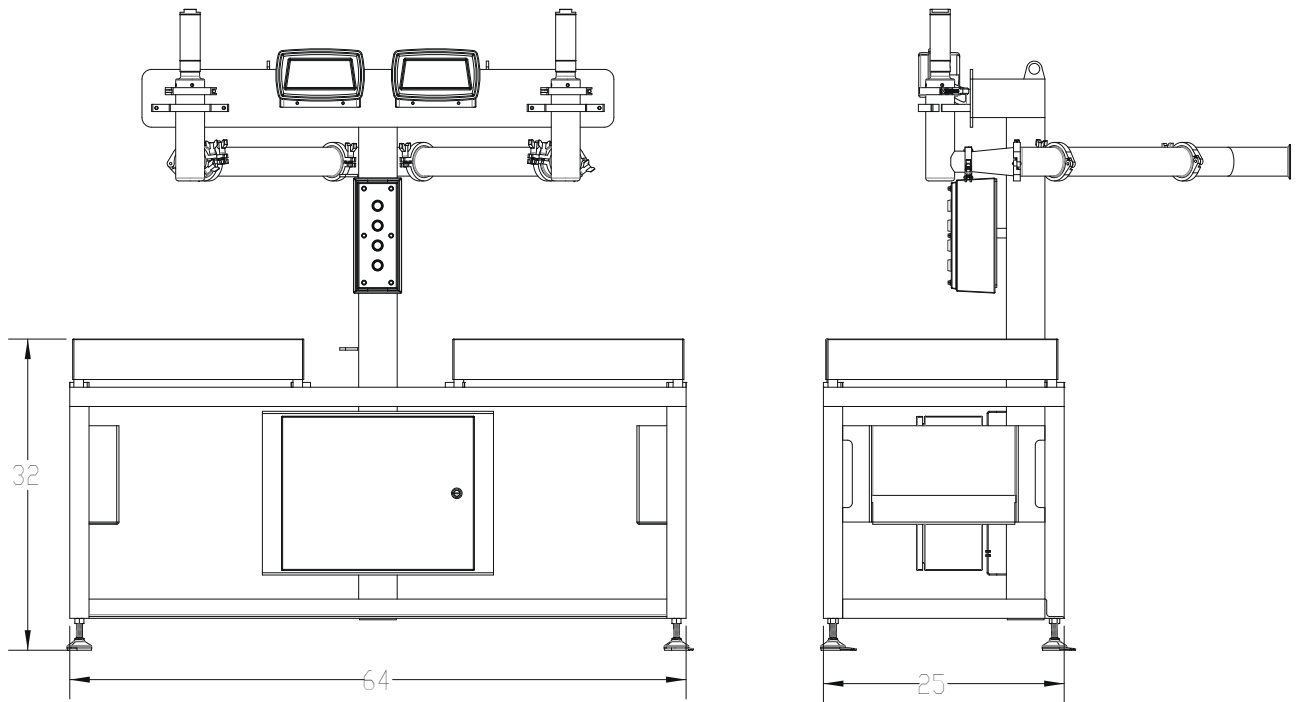

Box Filling Station

TECH SPECS

INPUT CAPACITY	Up to 10,000 kg/hr (22,000 lbs/hr)
STANDARD CONFIGURATION	CAS X320 Scale Heads
MACHINE POWER	120 VAC, 80 Psi Air
SANITATION	Easily Disassembled
BOX FILL OPTION	Horizontal or Vertical
STANDARD BOX	20 kg (44 lbs)
SCALE BED OPTIONS	Roller Top or Flat
CONTROLS	Stand Alone or Integrated

NOTES:

"World Leader in Quality Separation Solutions since 1978"