

# Infeed Belt Conveyor

## EQUIPMENT HIGHLIGHTS

- Up to 1,400 kg (3000 lbs) surge capacity.
- Full sanitary design.
- Metal free zone.
- Cascading drip pans.
- Full stainless gearmotor.
- Modular belting.

**“POSS Conveyors  
Maintain Low Cost of  
Ownership, Sanitary  
Design and are Fully  
Customizable”**

“World Leader in Quality Separation Solutions since 1978”



A DURAVANT COMPANY

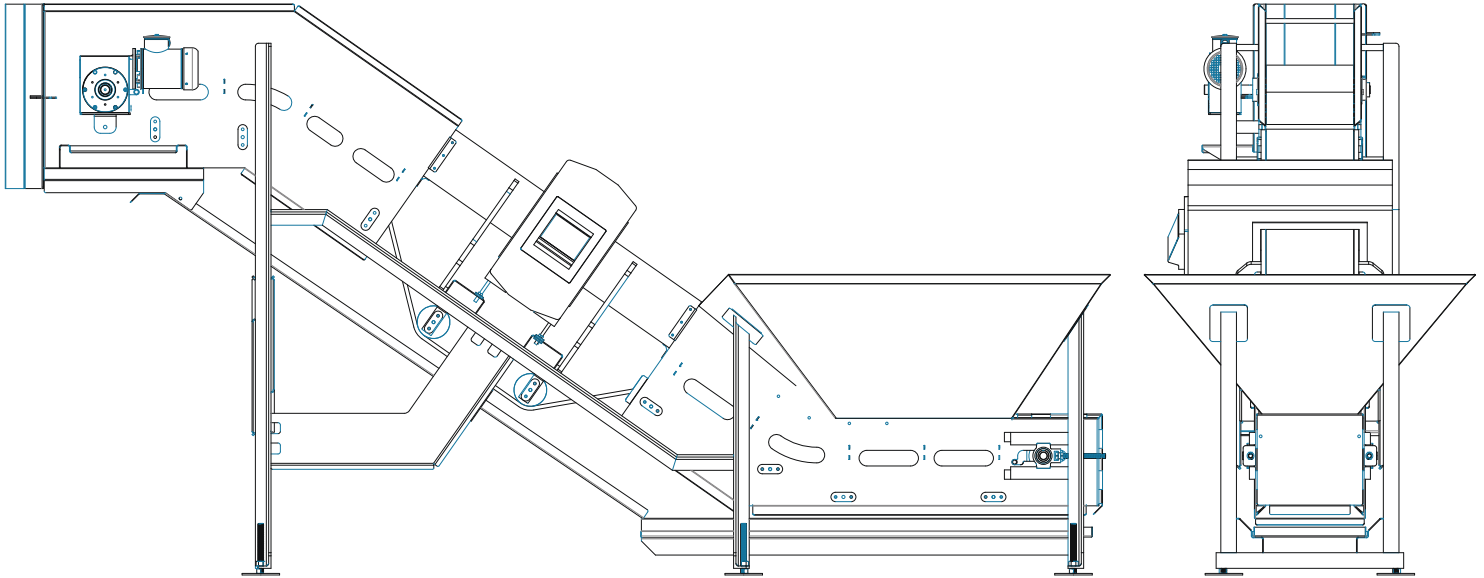

# Infeed Belt Conveyor

## TECH SPECS

HOPPER CAPACITY	Up to 1,400 kg (3000 lbs)
DISCHARGE HEIGHT	Customizable
POWER	Up to 2hp
SANITATION	Open Channel Design
METAL DETECTOR	Built to Suit
HOPPER AGITATOR	Optional
BELTING	Modular/Customizable
CONTROLS	Stand Alone or Integrated

## NOTES:

---



---



---



---



---



---



---



---

"World Leader in Quality Separation Solutions since 1978"