



A DURAVANT COMPANY



ProMax 1000

EQUIPMENT HIGHLIGHTS

- 1,000 kg/hr (2,200 lbs/hr) input capacity.
- 5" Separation screw (single or dual screws).
- 5" Head length (screen plates or perforated).
- 20 hp (15 kW) Motor.
- POSS Manual Restrictor.
- Integrated head cover & residue chute.

“POSS Maintains the Highest Yields and Lowest Temperature Rise in the Industry”

“World Leader in Quality Separation Solutions since 1978”



A DURAVANT COMPANY

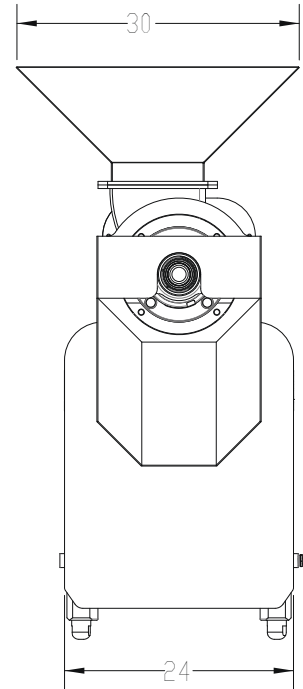
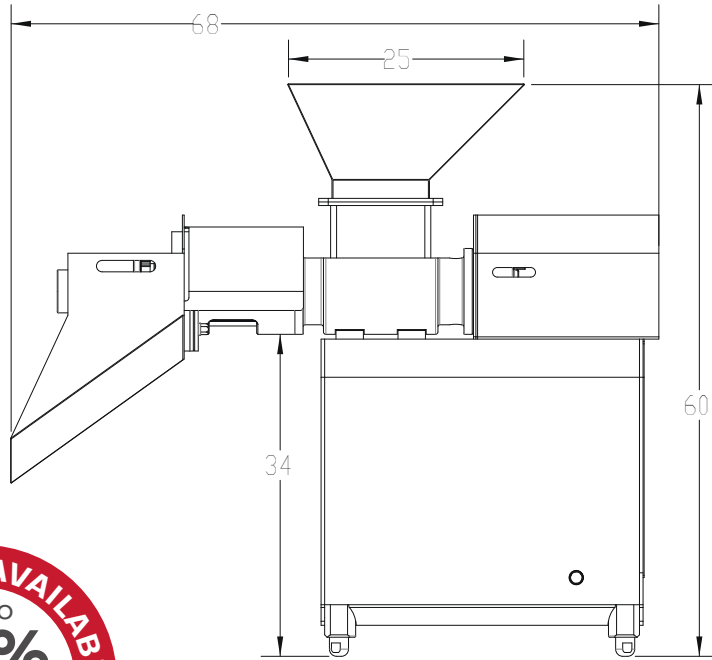

ProMax 1000

TECH SPECS

INPUT CAPACITY	Up to 1,000 kg/hr (2,200 lbs/hr)
STANDARD CONFIGURATION	5" Single or Dual Screws
MACHINE POWER	20 hp (15 kW)
TRANSMISSION	Extruder Belt Drive
HOPPER GEOMETRY	10" x 10"
HOPPER EXTENSION	Standard - 25" x 30"
HEAD GEOMETRY	5" x 5"
CONTROLS	HMI Control Panel with Line Integration or Simple Start/Stop

NOTES:

"World Leader in Quality Separation Solutions since 1978"