

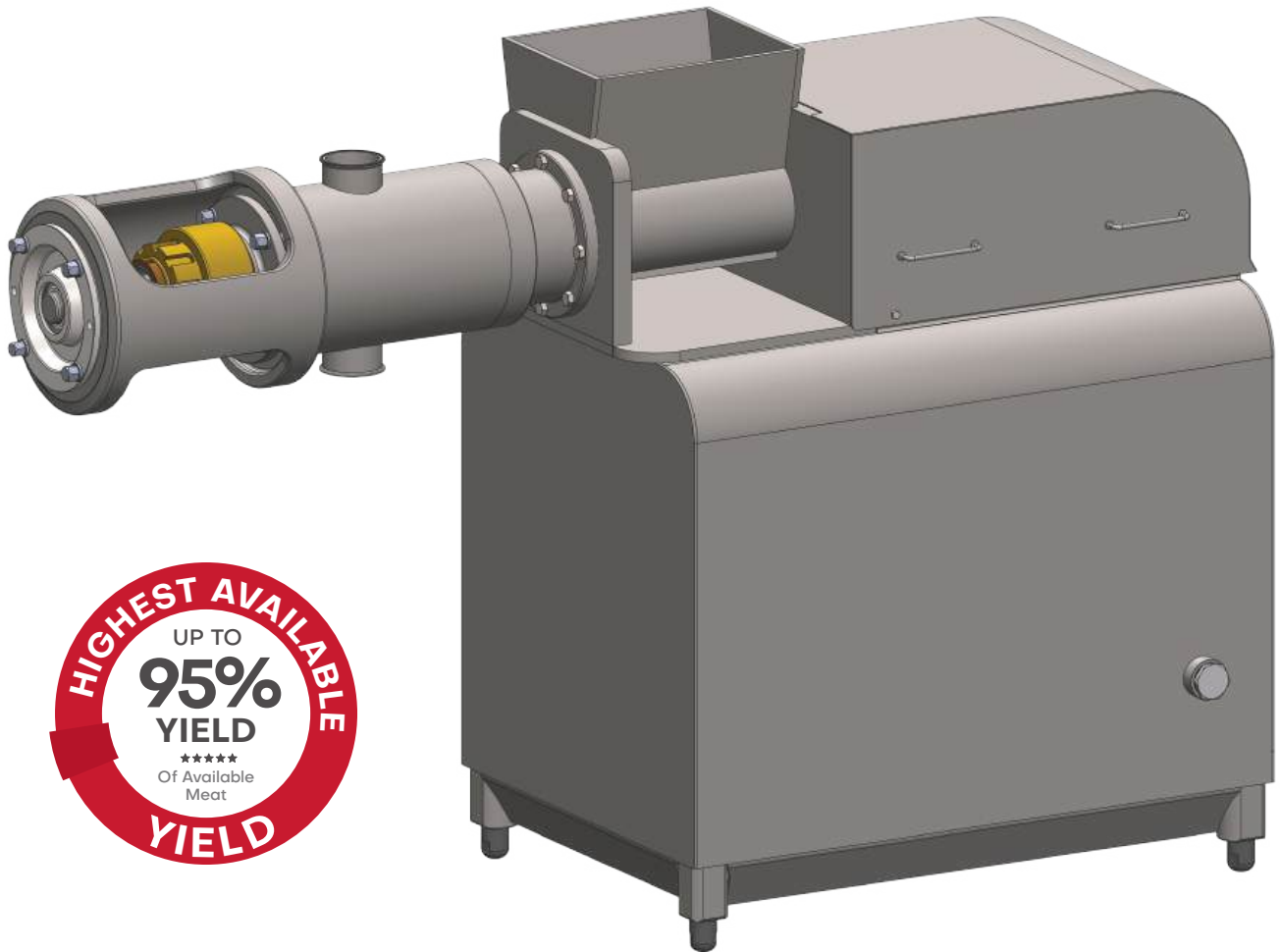

A DURAVANT COMPANY



ProMax6000 AMR

EQUIPMENT HIGHLIGHTS

- 5,000 kg/hr (11,000 lbs/hr) input capacity.
- 6" Separation screw (dual screws).
- 10" Head length (perforated screen).
- 40-60 hp (37-45 kW) Motor.
- POSS Integrated Inline Pump Assembly.
- Piped Product Head (4" Triclamp).

“POSS Maintains the Highest Yields and Lowest Temperature Rise in the Industry”

“World Leader in Quality Separation Solutions since 1978”



A DURAVANT COMPANY

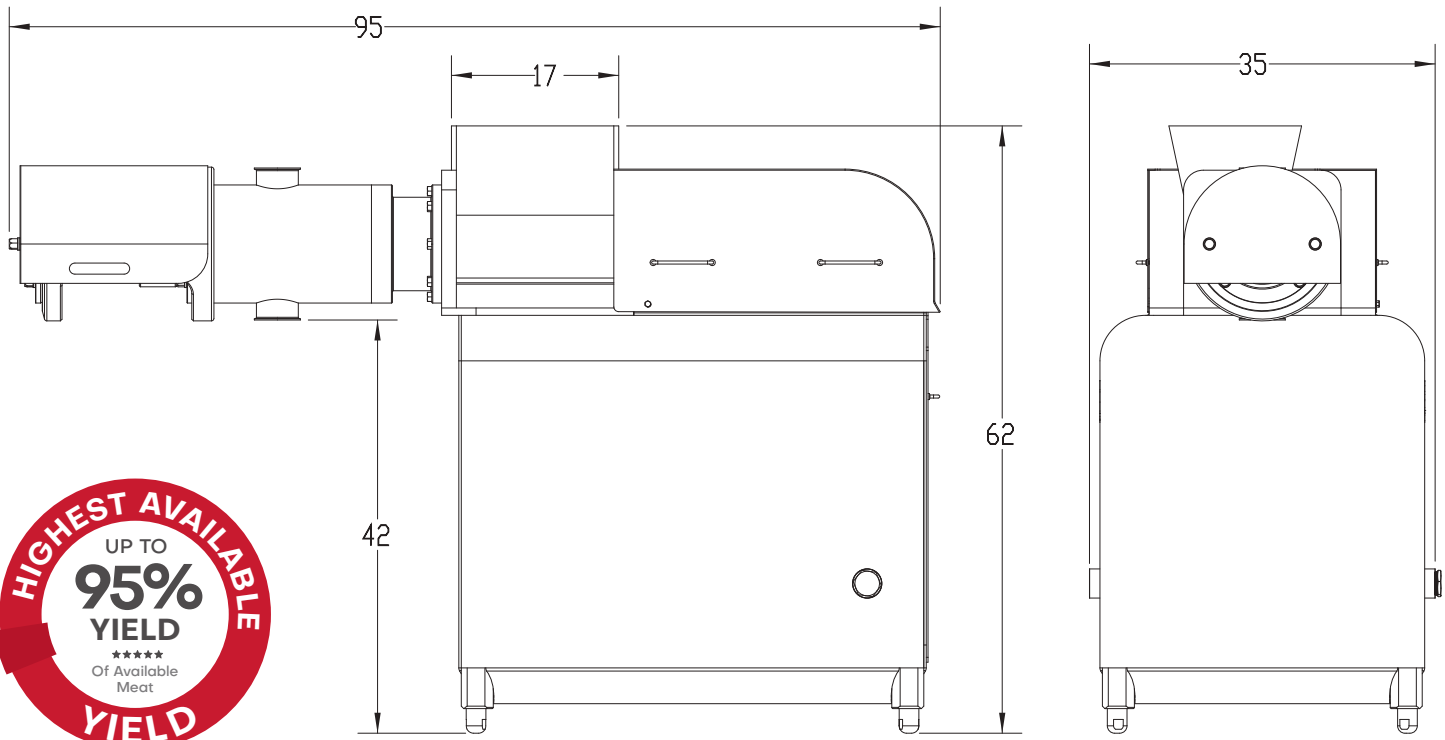

ProMax6000 AMR

TECH SPECS

INPUT CAPACITY	Up to 5,000 kg/hr (11,000 lbs/hr)
STANDARD CONFIGURATION	6" Dual Screws
MACHINE POWER	40-60 hp (37-45 kW)
TRANSMISSION	Extruder Belt Drive
HOPPER GEOMETRY	17" x 13"
HOPPER EXTENSION	Customizable
HEAD GEOMETRY	6" x 10" (Head Shroud Available)
CONTROLS	HMI Control Panel with line integration

NOTES:

"World Leader in Quality Separation Solutions since 1978"